

Installation and Operating Instruction

EPR Series Energy-saving Pipeline Canned Motor Pump
with speed control via PWM signal
for heating and solar systems



www.hst-industrie.at

Heiz- und Sanitärtechnik GmbH

Ziegeleistraße 1

5020 Salzburg / AUSTRIA

TABLE OF- CONTENTS

Table of Contents

Installation dimensions & technical data	5
1. Overview	8
2. Service conditions.....	9
3. Installation	10
4. Electrical connection	13
5. Control panel	14
6. Setting of electric pump	15
7. Night Mode (Auto).....	17
8. PWM Signal Control Mode.....	18
9. Use of bypass valve	21
10. Startup	22
11. Settings and performance of pump	23
12. Performance curve.....	24
13. Characteristics	27
14. Technical data and installation dimension.....	28
<i>Startwatt – Power input – Model – Voltage - Current</i>	29
15. Fault checklist	30

DIMENSIONS & TECHNICAL DATA

INSTALLATION DIMENSIONS & TECHNICAL DATA

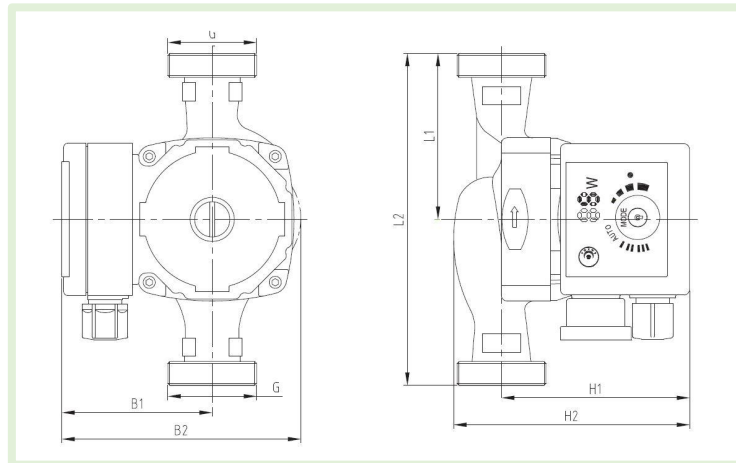

Model	Size (mm)							Connection
	L1	L2	B1	B2	H1	H2	G	
HST EPR 25-4 180	90	180	82	130	103	130	1½"	1"
HST EPR 25-6 180	90	180	82	130	103	130	1½"	1"
HST EPR 25-8 180	90	180	82	130	103	130	1½"	1"
HST EPR 32-4 180	90	180	82	130	102	132	2"	1¼"
HST EPR 32-6 180	90	180	82	130	102	132	2"	1¼"
HST EPR 32-8 180	90	180	82	130	102	132	2"	1¼"
HST EPR 20-6 130	65	130	52	99	103	127	1"	¾"
HST EPR 25-4 130	65	130	52	99	103	130	1½"	1"
HST EPR 25-6 130	65	130	52	99	103	130	1½"	1"

	max.head	max. Flow	power consumption	voltage	mains frequency
HSTEPR 25-4 180	4m	2,5 m³/h	5 – 22 Watt	230V	50 Hz /60 Hz
HSTEPR 25-6 180	6m	3,2 m³/h	5 – 45 Watt		
HSTEPR 25-8 180	8m	4 m³/h	5 – 70 Watt		
HSTEPR 32-4 180	4m	3 m³/h	5 – 22 Watt		
HSTEPR 32-6 180	6m	4 m³/h	5 – 45 Watt		
HSTEPR 32-8 180	8m	5 m³/h	5 – 70 Watt		
HSTEPR 20-6 130	6m	2,8 m³/h	5 – 45 Watt		
HSTEPR 25-4 130	4m	2,5 m³/h	5 – 22 Watt		
HSTEPR 25-6 130	6m	3,2 m³/h	5 – 45 Watt		

Precautions for use of EPR Series products:

1. The installation manual should be read carefully before installation and use.
2. Any failure to comply with the content marked by safety warning marks may cause personal injury, pump damage and other property loss, for which, the manufacturer shall not assume any responsibility and compensation.
3. Installer, operator and user must comply with the local safety regulations.
4. The user must confirm that installation and maintenance of the product should be conducted by staff proficient in the instructions and having professional qualification certificates.
5. Pumps must not be installed in damp environment or places that may be splashed by water.
6. In order to facilitate maintenance, one stop valve should be installed on each side of the pump inlet and outlet respectively.
7. The power supply of pump should be cut off during installation and maintenance.
8. Pump with copper or stainless steel body should be adopted to the domestic hot water Circulation.
9. The heat feed pipeline should not be supplemented with non-softened water frequently to avoid an increase in the calcium in the circulating water of pipeline so as not to clog impellers.
10. It is prohibited to start the pump when there is no pumping liquid.
11. Some models are not suitable for pumping drinking water.
12. Pumping liquid may be of high temperature and pressure, therefore, liquid in the system should be drained off or stop valves on both sides of the pump must be switched off to avoid burns before moving and removing pump.
13. Liquid of high temperature and pressure will flow out if exhaust bolts are removed; care must be taken to ensure that the liquid flowing out will not cause personal injury or damage to other parts.
14. In the summer or when the ambient temperature is high, attention should be paid to ventilation so as to prevent moisture condensation and cause electrical fault.
15. In the winter, if the pump system does not operate or when the ambient temperature is below 0°C, liquid in the pipeline system should be emptied to avoid causing frost crack to the pump body.
16. If the pump does not use for a long time, please turn off the conduit valves on pump inlet and outlet ends and cut off the power of pump.
17. If the flexible cord is damaged, please connect service center to have it replaced together with the connector.
18. If it is found that the motor is burning hot and abnormal, immediately turn off the valve on the pump inlet end and cut off the pump power, besides, immediately contact your local dealer or service center.

19. If the pump failure can not be cleared in accordance with the description in the instructions, immediately turn off the valve on the pump inlet end and cut off the pump power, besides, immediately contact your local dealer or service center.
20. The product should be placed out of the reach of children, after installation, isolation measures should be taken to prevent children from touching.
21. The product should be placed in a dry, ventilated and cool place and stored at room temperature.
22. This appliance can be used by children aged from 8 years and above and persons with reduced physical, sensory or mental capabilities or lack of experience and knowledge if they have been given supervision or instruction concerning use of the appliance in a safe way and understand the hazards involved. Children shall not play with the appliance. Cleaning and user maintenance shall not be made by children without supervision.



Warning

Before starting installation, the *Installation and Operating Instructions* of device must be read carefully. Installation and use of the device must comply with local regulations and follow good operation specification.



Warning:

Personnel with physical decline, dysesthesia or poor mental ability and lacking of experience and relevant knowledge (including children) should use the pump under the supervision and guidance of people who can take charge of their safety.

Symbol description



Warning:

Failure to comply with this security declaration will likely result in personal injury!



Failure to comply with this security declaration will likely cause failure or damage to the equipment!



Notes or instructions facilitating the work and ensuring operational safety.

1. OVERVIEW

1.1 EPR series circulating pump is mainly used for the water circulation in homeheating and domestic hot water system.

EPR series circulating pump is most suitable for the following system:

1. Stable heating system with variable flow
2. Heating system with variable pipeline temperature
3. Heating system with night mode
4. Solar system
5. Industrial circulation system
6. Home heating and domestic water supply system

EPR series circulating pump is equipped with a permanent magnet motor and differential pressure controller which can adjust the performance of electric pump automatically and continuously to meet the actual needs of the system.

EPR series circulating pump is equipped with control panel on the frontside, which is convenient for the operation of users.

1.2 Advantages of installation of EPR series circulating pump

1. Easy installation and start-up
2. EPR series circulating pump has Autoadaptation mode AUTO (factory settings).
3. In most cases, you can start the pump without need to make any adjustments and automatically adjust it to meet the actual needs of the system.
4. High comfort
5. The running noise of pump and the whole system is low.
6. Low energy consumption
7. Compared with the conventional circulating pump, its energy consumption is very low.
8. The minimum energy consumption of EPR series circulating pump can reach 5W.

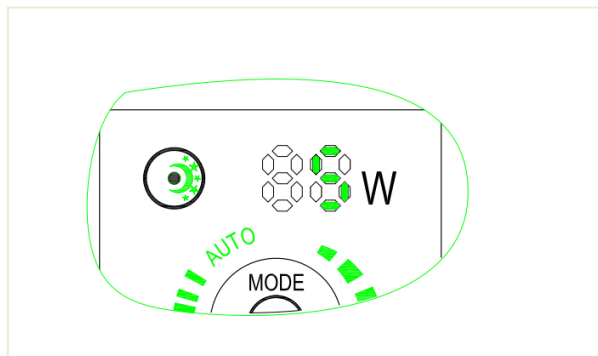

2. SERVICE CONDITIONS

2.1 Ambient temperature

The ambient temperature is 0°C~+40°C.

2.2 Relative humidity of the air (RH)

The maximum humidity is 95%.

2.3 Media (conveying liquid) temperature

Temperature of liquid conveying +2°C~110°C. To prevent the control box and stator from appearing condensate water, the temperature of pump conveying liquid must be always higher than the ambient temperature.

2.4 System pressure

The maximum is 1.0 Mpa (10 bar).

2.5 Protection Level

IP42

2.6 Inlet pressure to avoid damage to the pump bearing caused by cavitation noise, the following minimum pressure should be maintained in the pump inlet:

Liquid temperature	< 85°C	90°C	110°C
Inlet pressure	0.05bar	0.28bar	1bar
	0.5m	2.8m	10m

2.7 Pumping liquid

Thin, clean, non-corrosive and non-explosive liquid does not contain any solid particles, fibers or mineral oil; the pump should not be used for conveying flammable liquid such as vegetable oil and gasoline absolutely. If the circulating pump is used for the case of high viscosity, the pump performance will reduce, therefore, when selecting a pump, the viscosity of liquid must be considered.

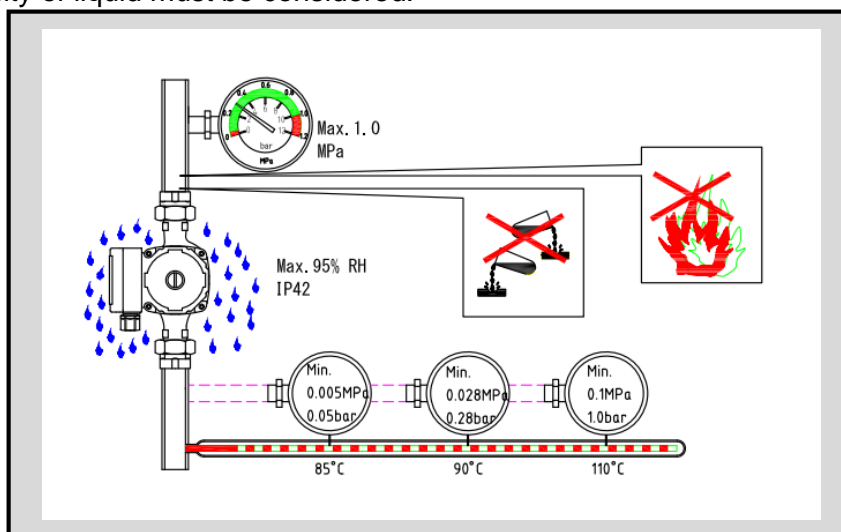

3. INSTALLATION

3.1 Installation

1. Install EPR series circulating pump, arrows on the pump housing indicate the direction of liquid flowing through the pump body.
2. When the pump is installed on the pipeline, its inlet and outlet must be installed with two leather packings provided.
3. During installation, the pump shaft must be in the horizontal position.

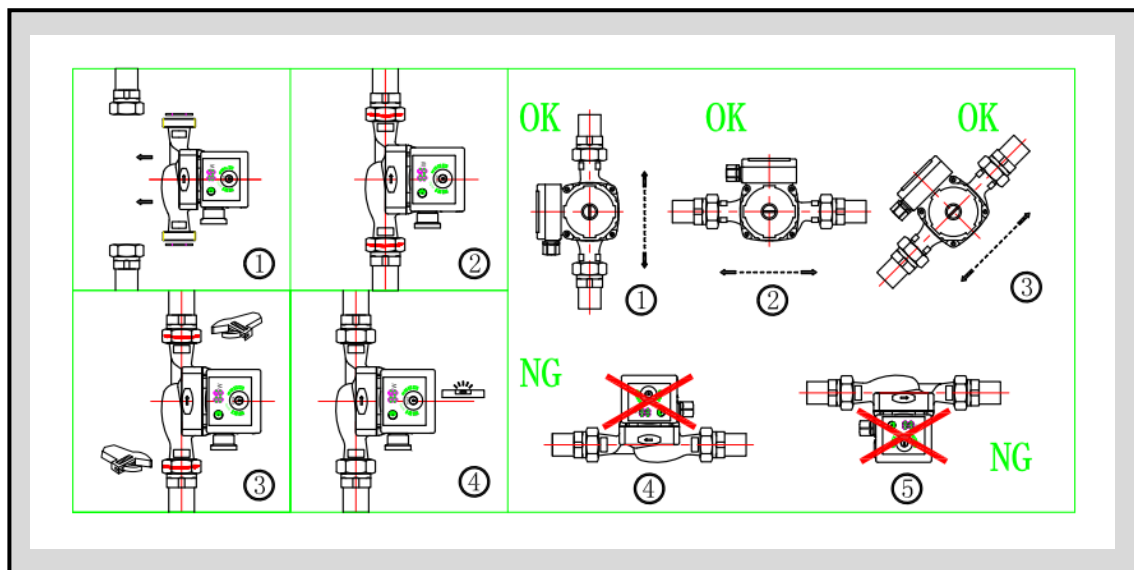

3.2 Position of junction box

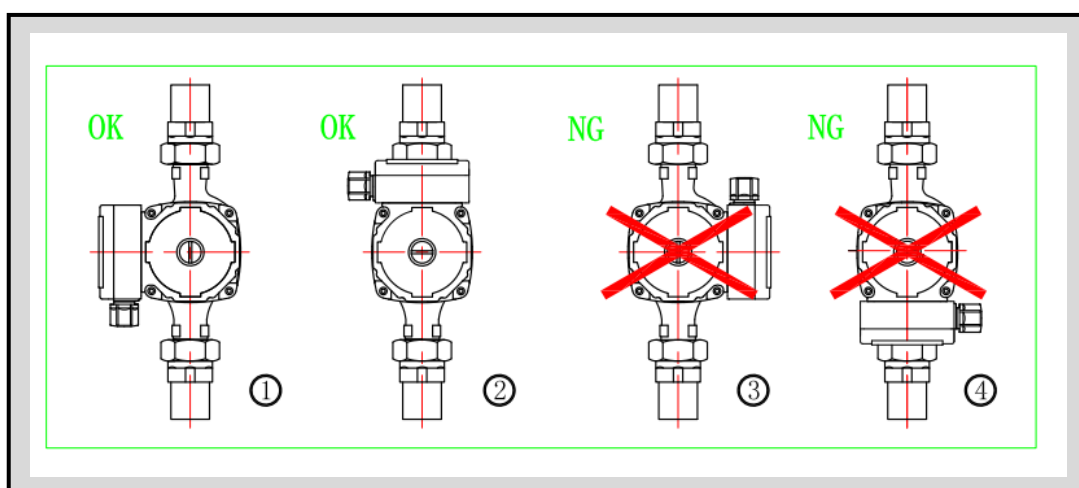

3.3 Change to the position of junction box

The junction box can rotate in 90°. To change the position of junction box, follow the operating steps below:

1. Close the valves at the inlet and outlet and release the pressure;
2. Loosen and remove the four socket head cap screws that fix the pump body;
3. Rotate the motor to the desired position and match the four screw holes;
4. Put the four socket head cap screws back and tighten them;
5. Open the valve of inlet and outlet.

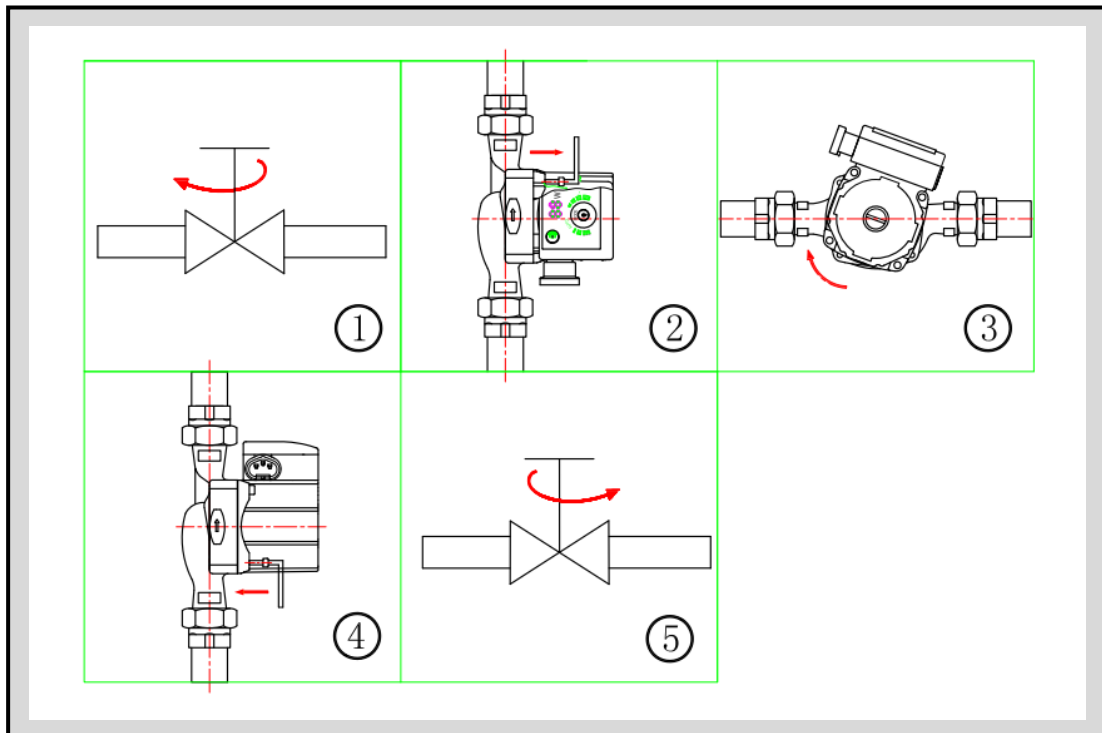

Warning:

Pumping liquid may be of high temperature and pressure, therefore, liquid in the system should be drained off or valves on both sides of the pump must be switched off before removing socket head cap screws.

Caution

Change the position of junction box, the pump should not be started until the system has been filled with pumping liquid or valves on both sides of the pump are open.

3.4 Thermal insulation of electric pump body

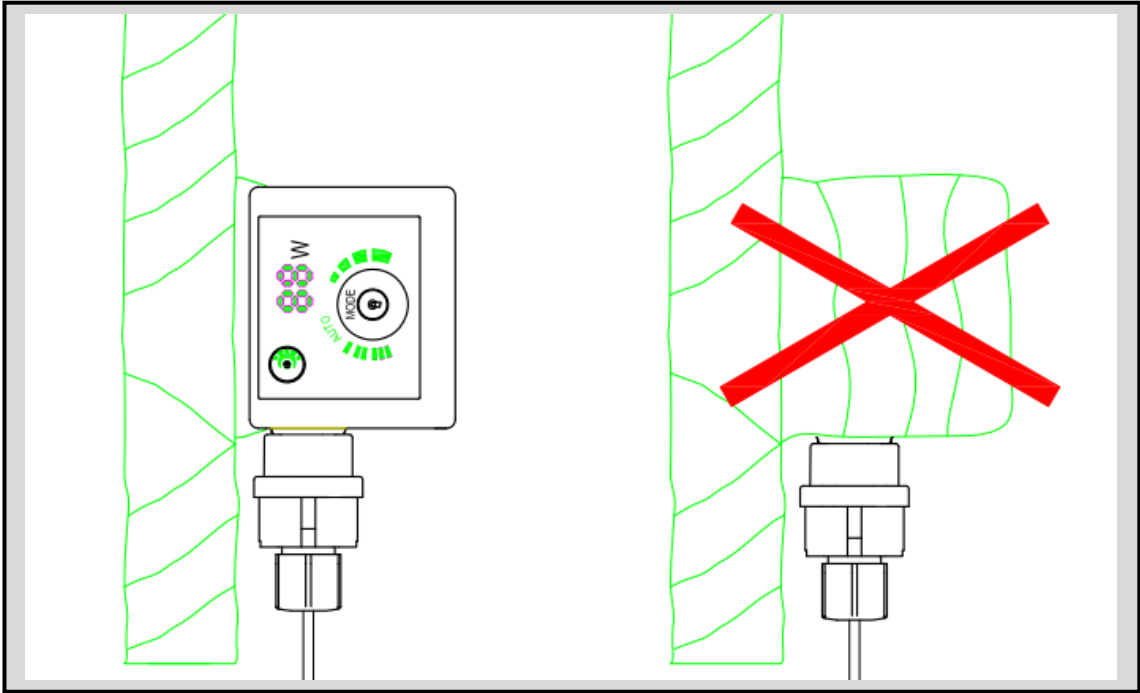

Note

Restrict the thermal losses of electric pump body and pipeline. Conduct thermal insulation for electric pump body and pipeline so as to reduce the thermal losses of pump and pipeline.

Caution

Isolating or covering junction box and control panel is not allowed.

4. ELECTRICAL CONNECTION

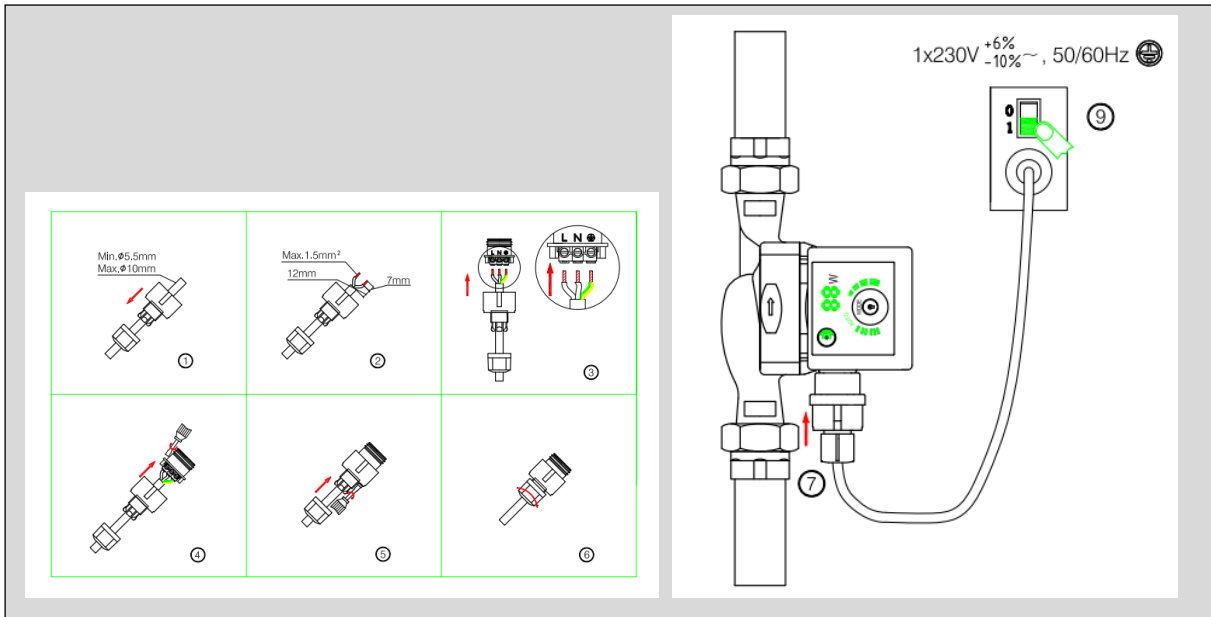

The pump can work with either a **power switch (power connection)** or **heating control** get connected.

Electrical connection and protection should be carried out in accordance with local regulations.



Warning:

The electric pump must be connected to earth wire 

The pump must be connected with an external power switch or heating control; the minimum gap between all the electrodes is 3 mm.

1. EPR series circulating pump does not need external motor protection.
2. Check whether the voltage of power supply and frequency match with the parameters marked by pump nameplate.
3. Use the pump associated plug to connect power supply.
4. If the indicator lamp on the control panel lights, it indicates that the power supply is switched on.

5. CONTROL PANEL

5.1 Components on the control panel

No.	Explanation
1	Indication lamp area in the Night Mode (AUTO)
	Butten to start or turn off Night Mode (AUTO)
2	Monitor that displays the actual power consumption of motor pump in Watt
3	Indication lamp area of eight operation modes set by motor pump
4	Button for setting operation modes of the motor pump

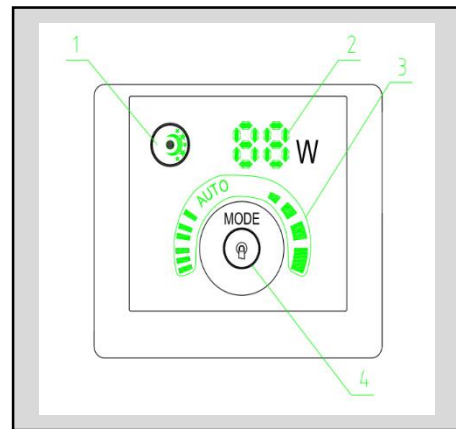

5.2 Indication lamp area of power consumption of motor pump

After the power is connected, the monitor in Position 2 works

During operation, the indicated value is in Watt, showing the actual power consumption of the motor pump

When the motor pump fails to work, the monitor indicates:

Code	Description
E0	Over-Voltage protection
E1	Under-Voltage protection
E2	Over-flow protection
E3	Under-load protection
E4	Over-phase protection
E5	Locked-rotor protection
E6	Motor start failure protection (Motor paramaters do not match)

If malfunction is detected, the power supply must be cut off before trouble-shooting. After the trouble is addressed, re-connect the power and start the motor pump

5.3 Indication Lamp Area of Motor Pump Setting

EPR series circulating motor pump has eight settings which can be chosen with the button. The motor pump settings are indicated with eight different indication lamp areas and display is controlled by PWM external signal.

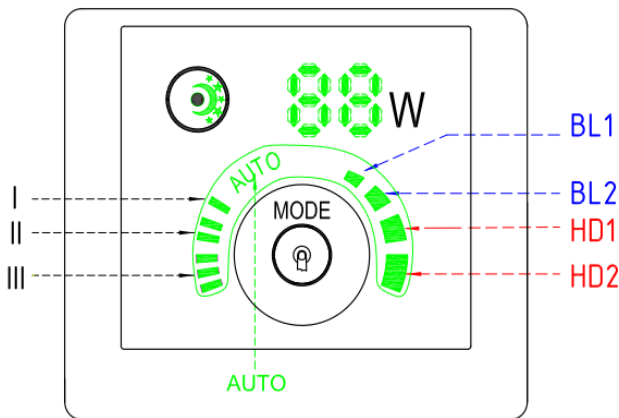

Button Times	Indication Lamp Area	Descriptions
0	AUTO (Initial settings)	Self-adaptive (AUTO)
1	BL1	Lowest Proportional Pressure Curve
2	BL2	Highest Proportional Pressure Curve
3	HD1	Lowest Constant Pressure Curve
4	HD2	Highest Constant Pressure
5	III	Constant Velocity Curve, Velocity III
6	II	Constant Velocity Curve, Velocity II
7	I	Constant Velocity Curve, Velocity I

5.4 Button for selecting motor pump settings

By pressing the button once at 2 seconds interval, the motor pump setting mode will change once. A cycle is constituted of every eight presses on button. For details, please refer to Section 5.3.

5.5 Button to Display Night Mode and Start Night Mode

When  is on, it indicates that the Night Mode is activated.

- Press this button to activate and deactivate Night Mode.
- Night Mode is only applicable to heating system equipped with this function.

Initial setting: Night Mode not set

Note If the motor has been set to Velocity I , Velocity II , Velocity III , then Night Mode Function cannot be selected.

6. SETTING OF ELECTRIC PUMP

6.1 The electric pump should be set according to system type

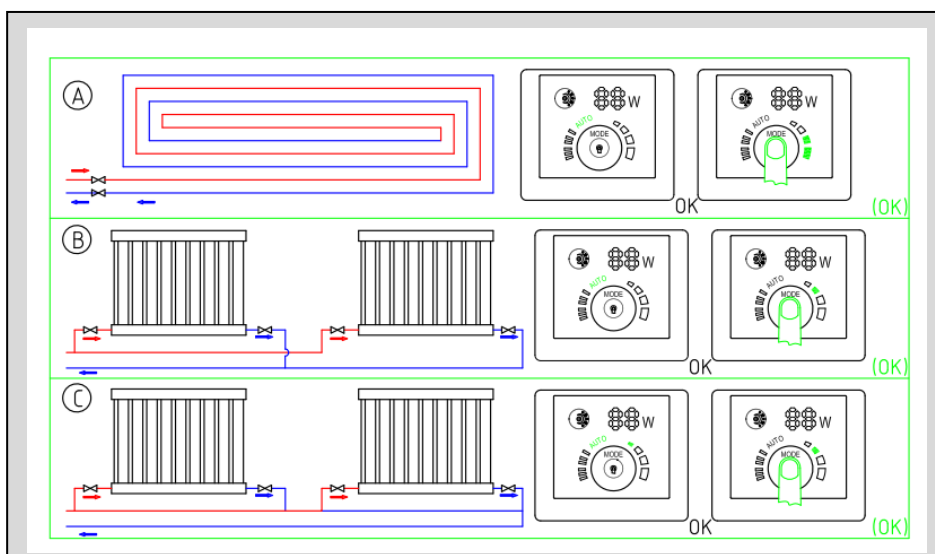

Factory settings=AUTO (autoadaptation mode)

Recommended and available settings of pump

Position	System type	Motor Pump Setting	
		Recommended	Options
A	Floor heating system	AUTO	HD1/HD2
B	Dual pipeline heating system	AUTO	BL2
C	Single pipeline heating system	BL1	BL2

1. AUTO (autoadaptation) mode shall adjust the pump performance automatically according to the actual heat demand of system. Since performance is adjusted gradually, it is recommended that leave it in the AUTO (autoadaptation) mode for at least a week before changing the settings of pump.
2. If you choose to change back to AUTO (autoadaptation) mode, EPR series pump can remember the set points of its previous AUTO mode and continue to adjust the performance automatically.
3. If you change Pump settings from one setting to other optional setting, Heating system is a slow system, it is impossible to achieve optimal operation mode within several minutes or hours. If the optimal settings of pump fail to achieve ideal heat distribution for each room, you should change the pump settings to other settings.
4. For the relationship between pump settings and performance curve, please see [Section 12.1](#).

6.2 The control on electric pump

During the operation of pump, control it according to "proportional pressure control" (BL) principle or "constant pressure control" (HD) principle.

In these two control modes, the performance of pump and corresponding power consumption should be adjusted according to the heat demand of system.

Proportional pressure control

In this control mode, the pressure difference on both ends of the electric pump shall be controlled by flow. Proportional pressure curve in Q / H diagram is represented by BL1/BL2 ([Section 12.1](#))

Constant pressure control

In this control mode, the pressure difference on both ends of the electric pump remains constant and is irrelevant to the flow rate. In Q/H figure, constant pressure curve is a level performance curve, represented by HD1/HD2 ([Section 12.1](#)).

A bypass valve system is fitted between the inlet pipeline and return pipeline

7. NIGHT MODE (AUTO)

7.1 Basic Principle

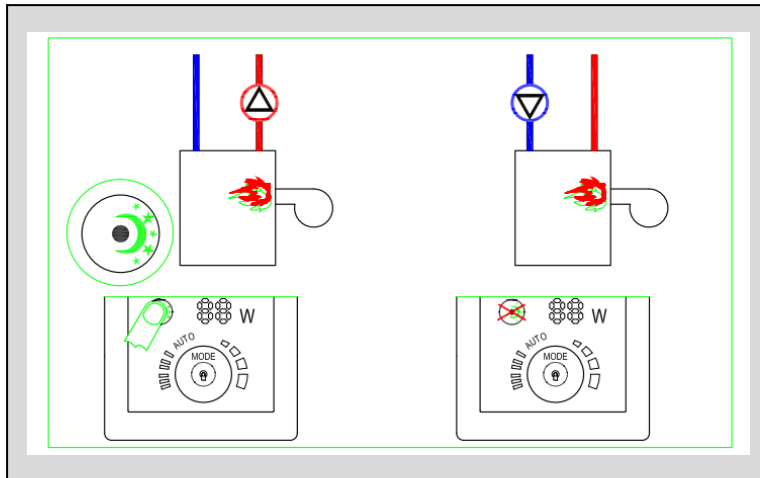

Warning

Night Mode is unavailable for the EPR series motor pump installed in gas boiler heating system with small water capacity.

Note

If Velocity I, Velocity II, or Velocity III mode have been selected, the Night Mode will be disabled.

Note

If power supply once has been cut off, then the Night Mode shall be restarted.

Note

If heat supply of the heating system is insufficient (not enough heat), then check if the Night Mode function is activated. If yes, disable the Night Mode function.

To ensure that the best status is realized in Night Mode, the following conditions must be satisfied:

The motor pump must be installed in the water inlet pipeline of the system and near the water outlet of boiler.

If the motor pump is installed in the water return pipeline of the system, then the Night Mode function will be disabled.

The system must be included with liquid temperature automatic control.

Press  button to activate night mode.

Please refer to [Section 11.1](#)

8.2 Night Mode Function

Once the Night Mode is enabled, EPR series motor pump will automatically switch between normal mode and Night Mode. The switching of EPR series motor pump between normal mode and Night Mode depends on the temperature of system inlet pipeline (not water return pipeline).

When the temperature drop of system inlet pipeline within two hours is higher than 10~15°C, EPR series motor pump will switch to Night Mode automatically. The temperature drop must be at least 0.1°C/min.

When the temperature of system pipeline rises about 10°C, it will switch to normal mode (time irrelevant).

8. PWM SIGNAL CONTROL MODE

8.1 Control and Signal

1) Control Principle

HST EPR series model pump is controlled by modulated LV PWM (Pulse Width Modulation) digital signal, which means that the variance of velocity depends on the external input signal. The variance of velocity is one of the functions of input control.

2) Digital LV PWM (Pulse Width Modulation) Signal

Design frequency scope of square wave PWM signal: 100Hz~2000Hz; PWM input signal (PWM IN) is used to give velocity commands, and adjusts the velocity commands through adjusting PWM duty cycle. PWM output signal (PWM OUT) is the feedback signal of the pump, and the PWM frequency is fixed at 75Hz±5%

3) Duty Cycle (d%)

$$d\% = t/T$$

For example :

$$T = 2 \text{ ms (500Hz)}$$

$$t = 0.6 \text{ ms}$$

$$d\% = 100 \times 0.6 / 2 = 30$$

$$U = 7 \sim 15V \text{ ich}$$

$$U \leq 1V \text{ iL}$$

$$I \leq 10mA$$

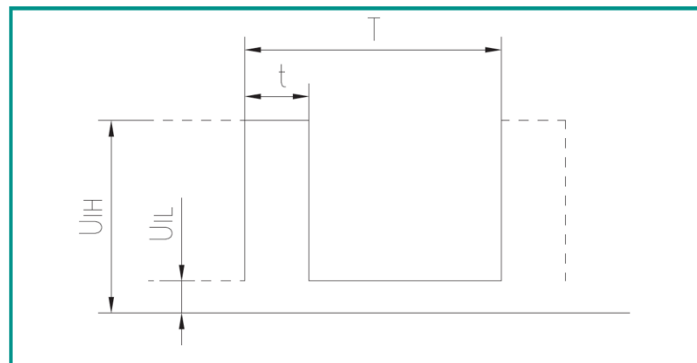

Code	Descriptions
T	Cycle
D	Duty Cycle
UiH	Input High Voltage
UiL	Input Low Voltage
IiH	Input Current

8.2 Interface

The pump is controlled by external electrical elements and components through interfaces. The interfaces convert external signals into signals that can be recognized by microprocessor in the pump. In addition, when the pump is supplied with 230V voltage, the interfaces can ensure that users will not be at risk of high voltage electric shock when contacting the signal cable.

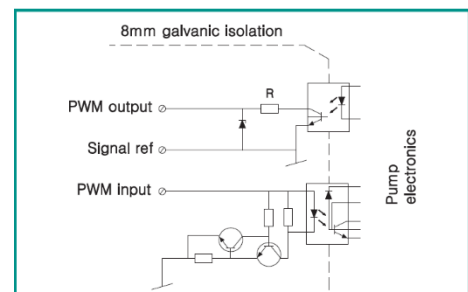

Note

“Signal Ref” is a reference earthing, and it is not connected to protective earthing

8.3 PWM Input Signal

- In area of high duty-cycle PWM signal, when the input signal fluctuates in the critical point, there will be a delay area to prevent frequent stop and start of the pump.
- In area of low duty-cycle PWM signal, the pump runs at high velocity for the sake of system safety. For instance, when the signal cable of gas boiler system is damaged, the pump will continue to run at the maximum rotational speed and transfer heat through main heat exchanger. This is also applicable to heat pump, ensuring continuous heat transfer in the case of signal cable of pump is damaged and system safety is guaranteed.
- When PWM input signal is 0% or 100%, the pump will switch to non-PWM mode (normal mode), and the default system will have no PWM signal input.

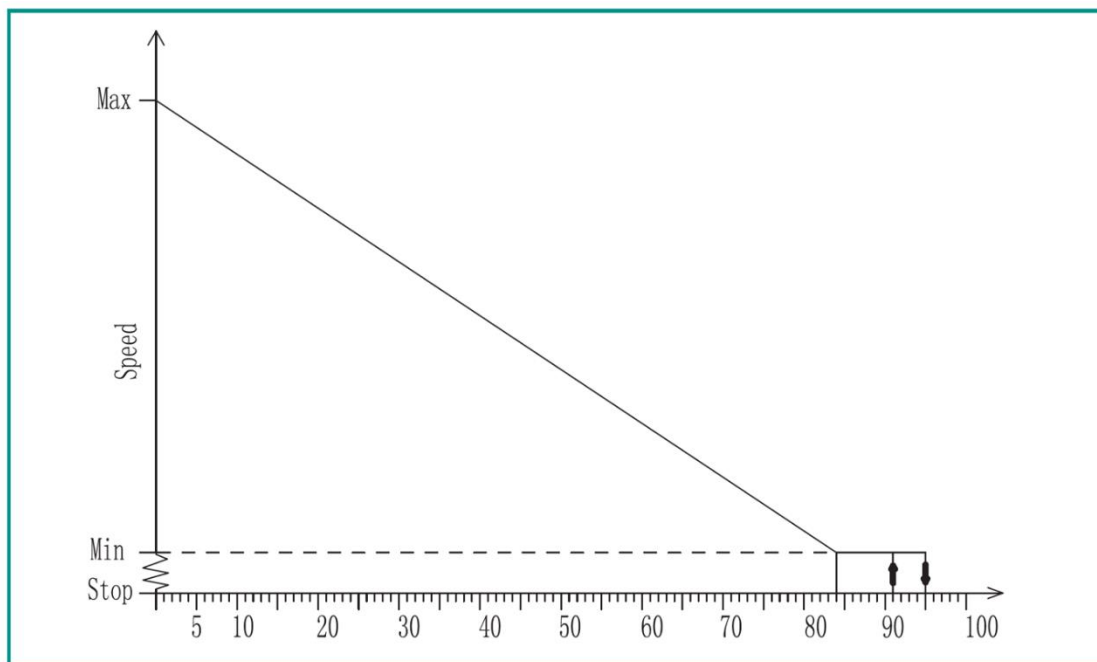

PWM Input Signal (%)	Pump Status
0	The pump switches to non-PWM mode (normal mode), and the default system will have no PWM signal input.
<10	The pump runs at the highest velocity
10~84	The pump curve will drop from the highest to the lowest
85~91	The pump runs at the lowest velocity
91~95	If the velocity variance point of input signal fluctuates, then it will block the start and stop of the pump according to the principle of magnetic hysteresis
96~99	Stand-by, the pump stops
100	The pump switches to non-PWM mode (normal mode) and the default system will have no PWM signal input.

Note

This System is adaptive to the automatic switching of PWM and non-PWM mode. When there is PWM signal input, the system will enter PWM mode.

8.4 PWM Feedback Signal

PWM feedback signal can provide operation status of the pump, such as power loss or all kinds of alarm/warning modes.

PWM feedback signal will feed back exclusive alarming information. If the power voltage detects under voltage signal values, its output signal will be set to 75%. Provided sundries settlement exists in the hydraulic system and causes rotor being blocked, the duty cycle of output signal is set to 90%, the alarm will be given higher priority.

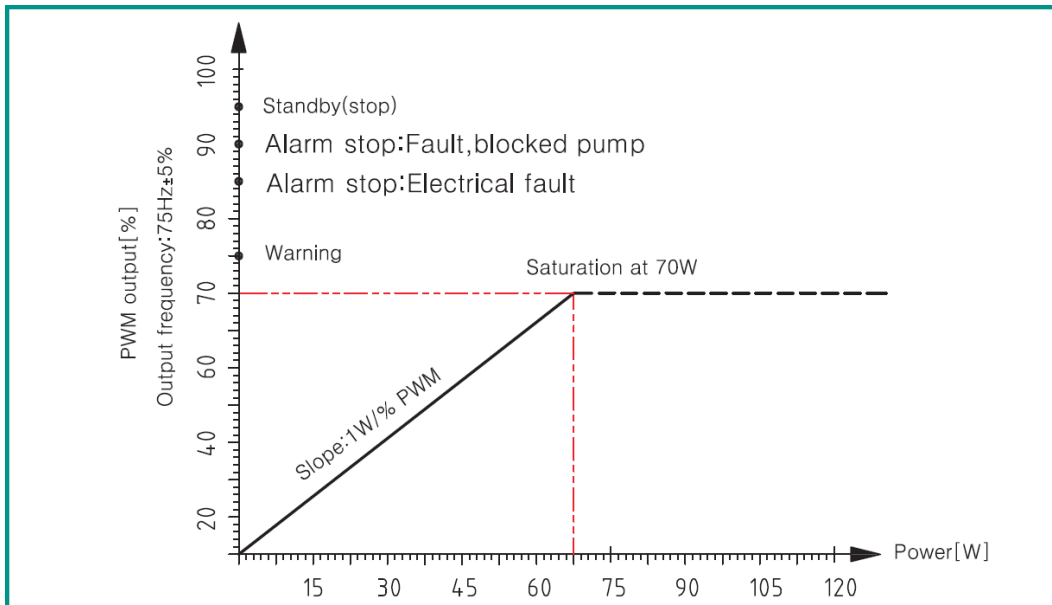

PWM Output Signal (%)		
95	Standby (stop)	The pump stops
90	Alarm stops, malfunctions (pump blocked)	The pump does not work and will restarts only after trouble is addressed
85	Alarm stops, electrical malfunction/trouble	The pump does not work and will restarts only after trouble is addressed
75	Warning	The pump runs, trouble has been detected under this situation but it is not critical, and the pump can still work.
0-70	0-70W (slope 1 W/% PWM)	

8.5 How to use the signals

The signal can be used to measure power consumption of the pump. The pump signal can be used to detect the actual operating point of the system rather than measuring by the current controlled by the system. The signal is also applicable to comparing velocity setting value and feedback.

9. USE OF BYPASS VALVE

Bypass valve

The role of bypass valve is: when all the valves in the floor heating circuit or the temperature control valve of radiator are closed, it can be ensured that the heat from the boiler will be assigned.

System components:

1. Bypass valve
2. Flowmeter, position L.

The minimum flow must be ensured when all valves are closed.

Water pump settings depend on the type of bypass valve it equipped with, i.e. manually-operated bypass valve or temperature-controlled bypass valve.

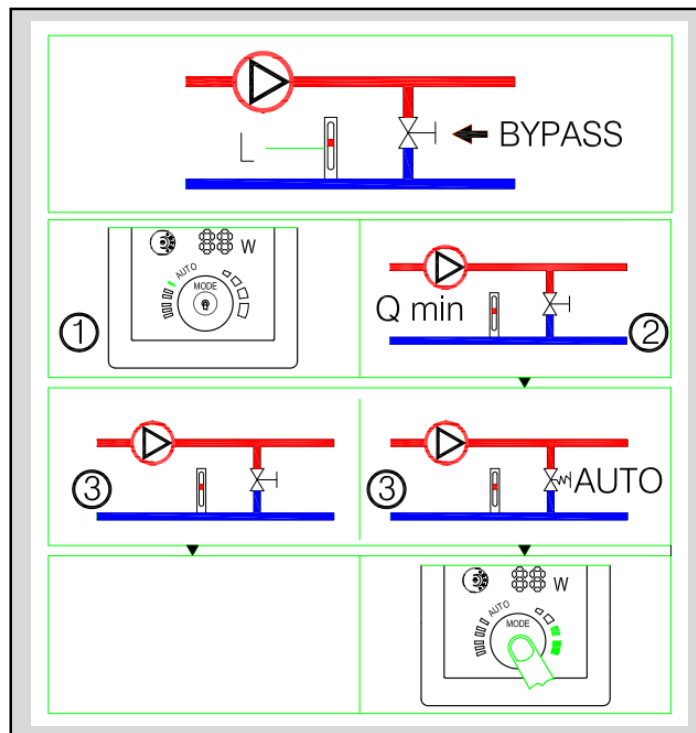

9.1 Manually-operated bypass valve

Follow the following steps:

1. When adjusting the bypass valve, the water pump should be in setting 1 (Velocity I Mode). The minimum flow rate (Q min) must always be ensured. See the manual of bypass valve manufacturer.
2. When the bypass valve has been adjusted, set the water pump referring to **Section 12.1 Pump Setting**.

9.2 Automatic bypass valve (temperature control type)

Follow the following steps:

1. When adjusting the bypass valve, the water pump should be in setting 1 (Velocity I Mode)
The minimum flow of system (Q_{min}) must always be ensured. See the manual of bypass valve manufacturer.
2. When the bypass valve has been adjusted, set the water pump to the constant pressure mode. For the relationship between pump settings and performance curve, please see Section 12.1. *Settings and Performance of Water Pump*.

10. STARTUP

10.1 Before startup

Before starting the electric pump, make sure that the system is filled with liquid, gas has been vented, and the electric pump inlet pressure must achieve the minimum inlet pressure as required (see Chapter 3).

10.2 Exhaust the Motor Pump

EPR series pump has automatic gas-exhausting function. There is no need for gas-exhausting before startup. Gas in the electric pump may cause noise.

The noise will disappear after putting it into operation for a few minutes. Set the EP series electric pump to be Velocity III mode in a short time according to the size and structure of system, then gas in the pump will be vented quickly. After gas-exhausting of pump, that is, after the noise disappears, set the electric pump according to the recommended instructions. Please refer to Chapter VII

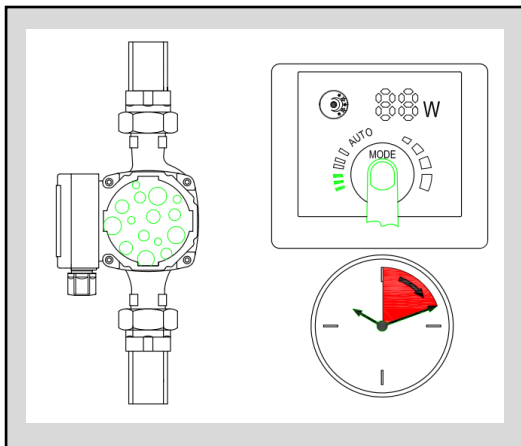

Gas-exhausting of heating system

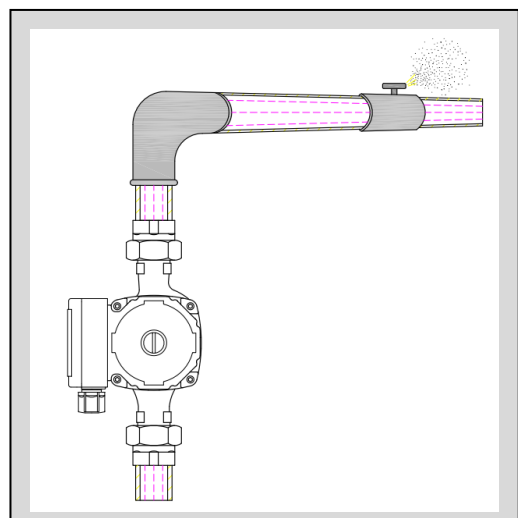



Caution

The pump should not operate without water

11. SETTINGS AND PERFORMANCE OF PUMP

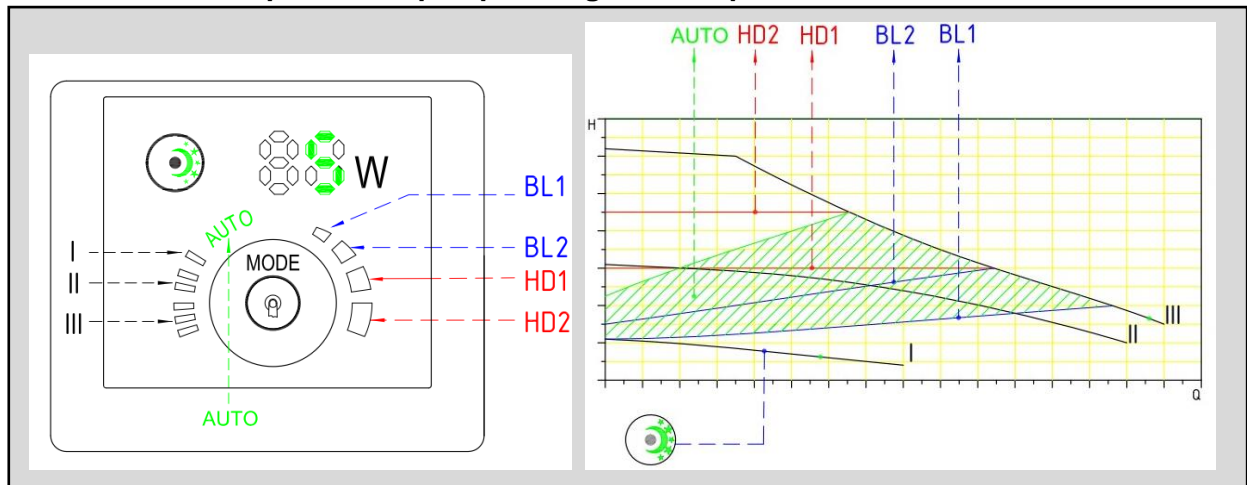
11.1 Relationship between pump settings and its performance



Settings	pump Characteristic curve	Function
AUTO (factory settings)	Highest to lowest proportional pressure curve	<p>"Autoadaptation" function will automatically control the water pump performance within the specified range.</p> <ol style="list-style-type: none"> 1. Adjust the performance of water pump according to the size of system; 2. Adjust the performance of water pump according to the load change of a period of time; <p>In the "Autoadaptation" mode, the water pump is set to proportional pressure control mode.</p>
BL1	Lowest Proportional pressure curve	The operating point of the pump will move up and down on the lowest proportional pressure curve based on the demand of system flow rate. When flow demand decreases, the pressure supply of pump drops, when flow demand increases, the pressure supply of pump rises
BL2	Constant pressure curve	The operating point of the pump will move up and down on the highest proportional pressure curve based on the demand of system flow rate. When flow demand decreases, the pressure supply of pump drops, when flow demand increases, the pressure supply of pump rises.
HD1	Lowest Constant Pressure Curve	The operating point of the pump will move around the lowest constant pressure curve based on the demand of system flow rate. The supply pressure of pump remains constant and it is irrelevant with the flow rate.
HD2	Highest Constant Pressure Curve	The operating point of the pump will move around the highest constant pressure curve based on the demand of system flow rate. The supply pressure of pump remains constant and it is irrelevant with the flow rate.
III	Velocity III	It runs on the constant curve in a constant Velocity. In the Velocity III mode, the pump is set to work on the highest curve under all working conditions. Setting the pump as Velocity III mode within short period of time can quickly vent the pump.
II	Velocity II	It runs on the constant curve in a constant velocity. In the Velocity II mode, the mode, the pump is set to work on the intermediate curve under all working conditions.
I	Velocity I	It runs on the constant curve in a constant velocity. In the Velocity I mode, the pump is set to work on the lowest curve under all working conditions.
		As long as certain conditions are met, it will switch to Automatic Night Mode and run in the lowest performance and power

12. PERFORMANCE CURVE

12.1 Performance curve guide

Each setting of the pump will have a corresponding performance curve (Q/H curve). While AUTO Autoadaptation mode covers one performance scope.

The area of PWM signal control performance curve (Q/H curve) is between motor pump velocity I~III

Input power curve (P1 curve) belongs to each Q/H curve. Power curve represents the power consumption of pump in given Q/H curve with Watt as the unit.

P1 value corresponds to the readings taken from the monitor of motor pump.

12.2 Curve conditions

The following description applies to the performance curves in EPR series manual:

- Testing liquid: gas-free water.
- Applicable density of curve $\rho = 983.2$ kg/cubic meter, and the liquid temperature is $+60$ °C.
- All curves represent averaged value, and shall not be used as guarantee curve. If a specific performance is needed, then separate measuring shall be conducted.
- Velocity I , II , III curves have all been marked.
- The applicable Kinetic viscosity of the curve $\nu = 0.474$ mm² / s (0.474CcST)

12.3 Performance curve

EPR XX-4 series

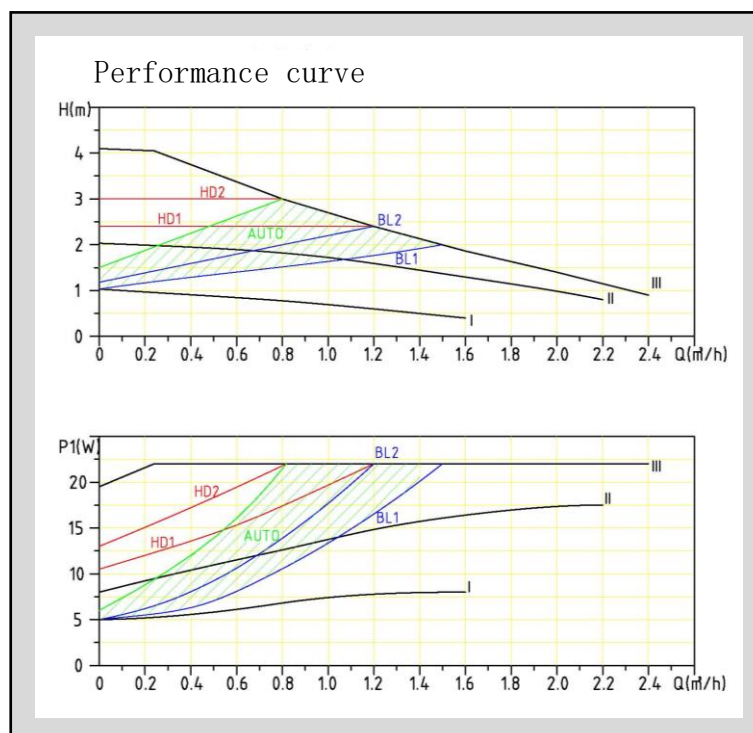

EPR XX-5 series

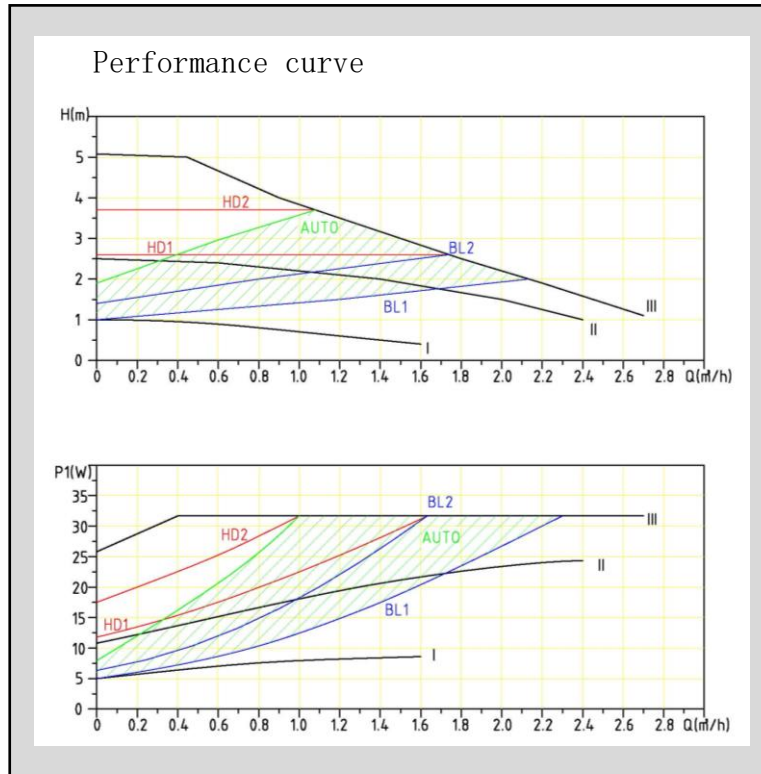

EPR XX-6 series

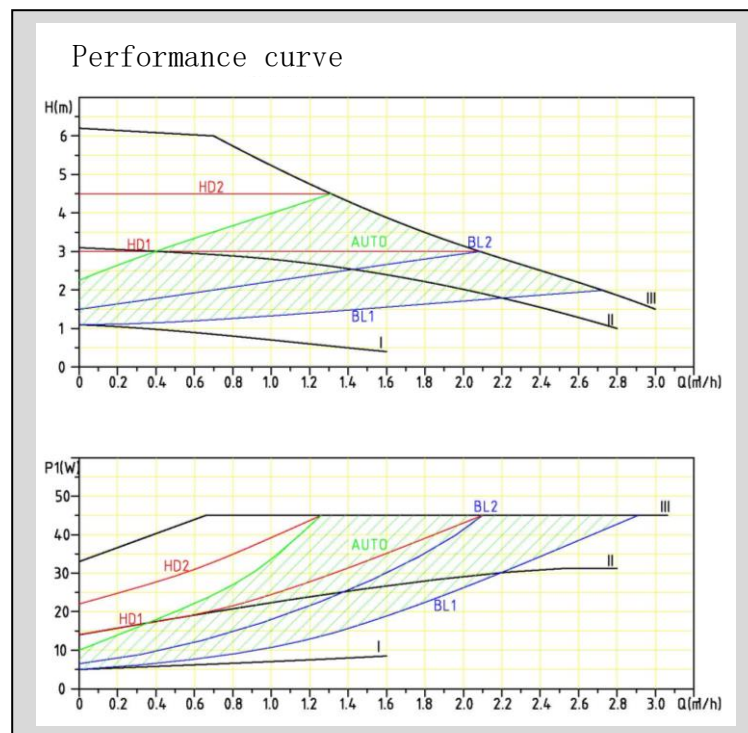

EPR 25-8 Serie

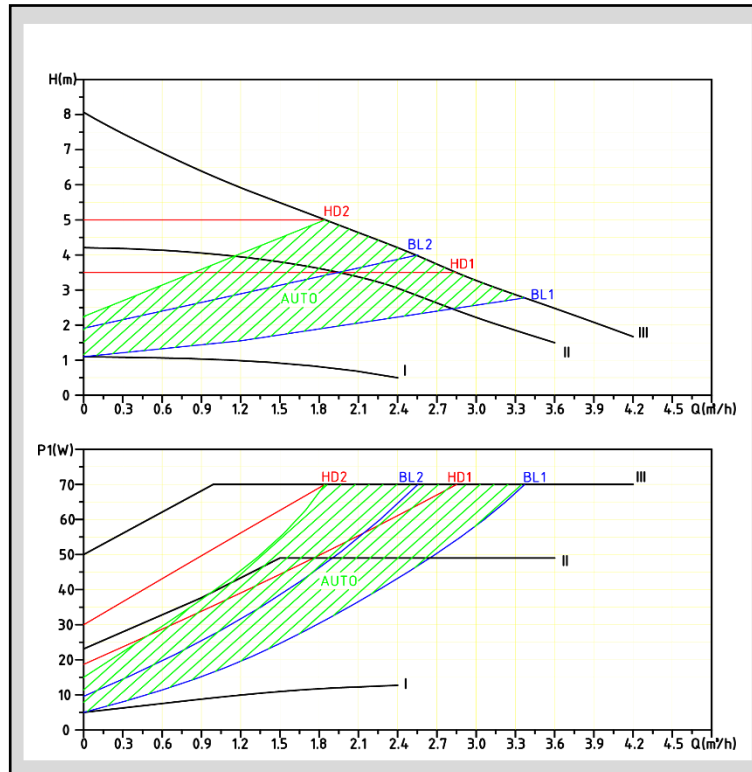

EPR 32-8 Serie

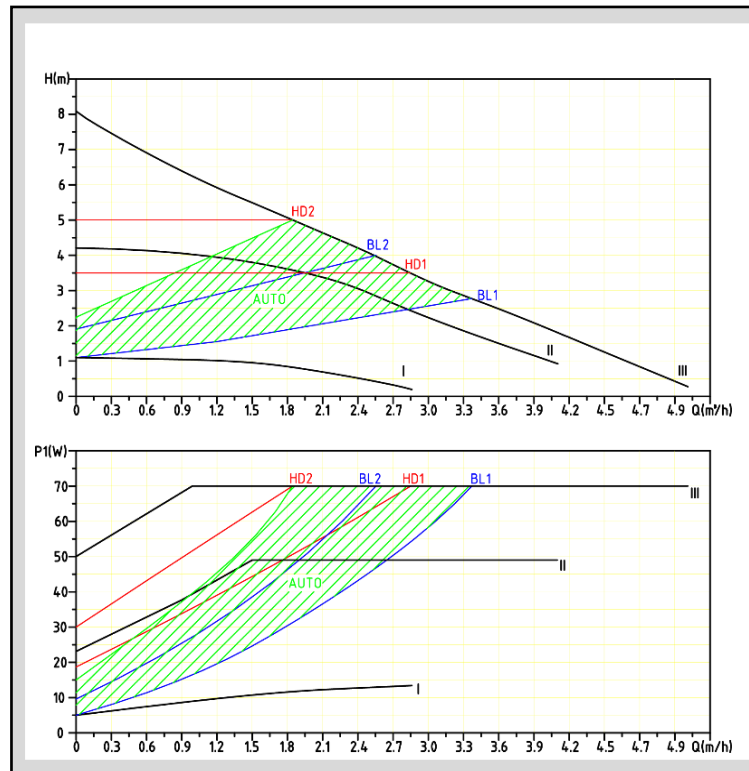

13. CHARACTERISTICS

13.1 Description of nameplate

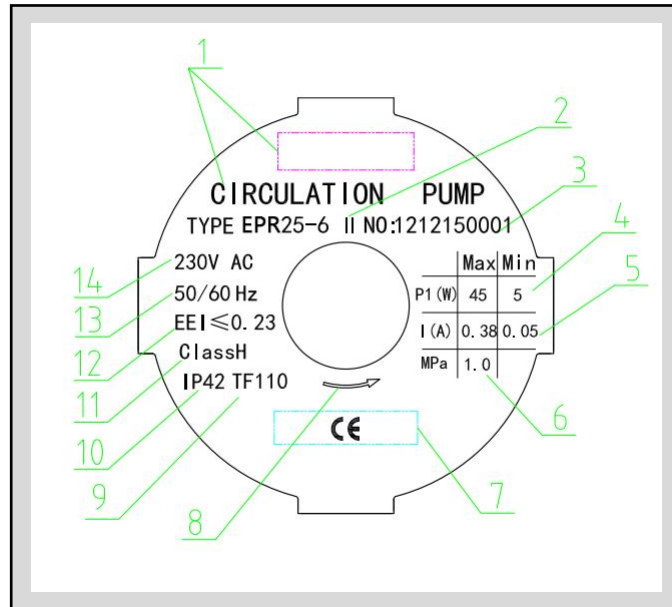

No.	Explanation	
1	Manufacturer Name	
2	Product Model	
3	Product	Digit 1 to digit 6 indicates manufacturing date
	No.	Digit seven to digit ten indicates serial number
4	Power (Watt)	Minimum mode minimum input power P1
		Maximum mode maximum input power P1
5	Current (Amp)	Minimum mode minimum current
		Maximum mode maximum current
6	Maximum pressure-bearing of system (MPa)	
7	Authentication mark	
8	Direction of rotation	
9	Temperature class	
10	Degree of protection	
11	Insulation class	
12	Energy Index	
13	Frequency (Hz)	
14	Voltage (v)	

13.2 Model explanation

Pump model is consisted of upper Latin letters and Arabic numerals etc., whose meanings are as follows:

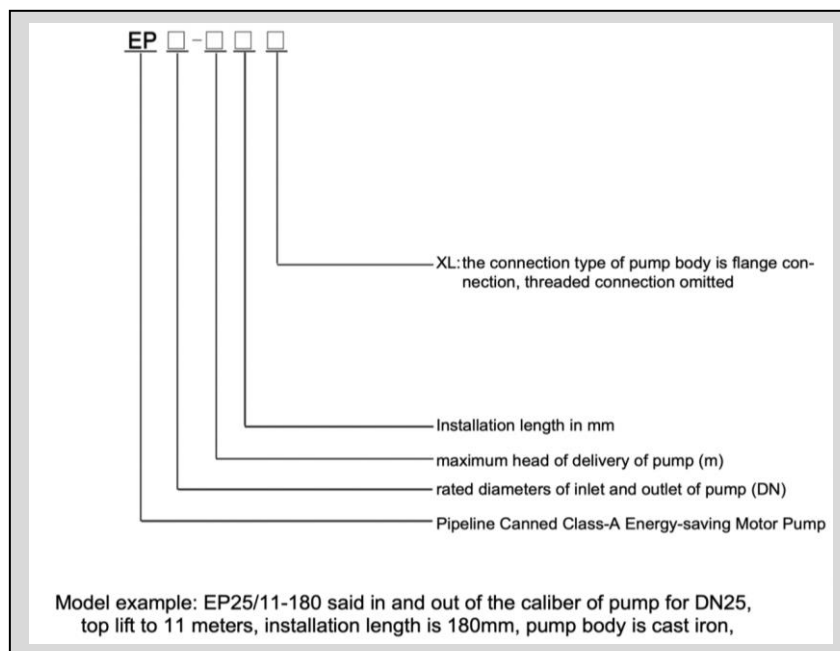

14. TECHNICAL DATA AND INSTALLATION DIMENSION

14.1 Technical data

Supply voltage	1x230V +6%/-10%, 50/60Hz, PE	
Energy-efficiency-index	EEI≤0.20	
Motor protection	Pump does not need external protection	
Protection Level	IP42	
Insulation class	H	
Environmental relative humidity of the air (RH)	Max95%	
Pressure-bearing of system	1.0 MPa (MPa)	
Suction inlet pressure	Liquid temperature	Minimum inlet pressure
	≤+85℃	0.005 MPa
	≤+90℃	0.028 MPa
	≤+110℃	0.100 Moa
EMC standards	EN61000-3-2 and EN61000-3-3 EN55014-1 and EN55014-2	
Sound pressure level	The sound pressure level of water pump is below 43dB (A)	

Ambient temperature	0~+40°C
Temperature grade	TF110
Surface temperature	Maximum surface temperature should not exceed +125°C
Liquid temperature	2~+110°C

To prevent the control box and stator from appearing condensate water, the temperature of pump conveying liquid must be always higher than the ambient temperature

Ambient temperature (°C)	Liquid temperature	
	Minimum (°C)	Maximum (°C)
0	2	110
10	10	110
20	20	110
30	30	110
35	35	90
40	40	70

In domestic hot water, it is recommended to keep the temperature of water below 65 °C so as to reduce scaling

Startwatt – Power input – Model – Voltage - Current

Startwatt (W) (at start)	Power input (W)	Model	Voltage (V)	Current (A)
14,7	22	EPR15-4 EPR20-4 EPR25-4 EPR32-4	220-240V 50/60Hz	0,19
21,3	32	EPR15-5 EPR20-5 EPR25-5 EPR32-5	220-240V 50/60Hz	0,27
30	45	EPR15-5.5 EPR15-6 EPR20-6 EPR25-6 EPR32-6	220-240V 50/60Hz	0,38
46,7	68	EPR20-8 EPR25-8 EPR32-8	220-240V 50/60Hz	0.51

15. FAULT CHECKLIST



Warning:

Before carrying out any maintenance and repair to the motor pump, make sure the power is disconnected and will not be connected accidentally.

Fault		Cause	Eliminating method
Pump fails to start	Indication lamp "off"	Fuse in equipment burned out	Replace fuse
		Breaker of current control or voltage control disconnects	Connect the breaker
		Electric pump failure	Replace the pump
	Indicating "E0"	Too low voltage	Check whether the power is within the specified range
	Indicating "E1"	Locked-rotor of electric pump (stuck)	Remove impurities
	Indicating "E2"	PCB component failure or motor failure	Return to factory maintenance
	Indicating "E3"	No water in the pump	Open the valve and supply water to the pump
System noise	Indicating "E4"	Enter the motor line disconnected	Return to factory maintenance
	Indicating "E5"	Rotor stuck	Remove the pump house and take out the rotor cleaning
System noise	Indicating "E6"	Motor resistance parameters do not match	Return to factory maintenance
	Indicating one value	Air exists in the system	Vent the system
Excessively high flow rate		Lower inlet pressure of the motor pump	
Noise in the pump		Air exists in the motor system	Vent the system
		Excessively low inlet pressure	Raise inlet pressure
		Dirt in the pump impeller (often in heating circuits without a filter)	Loosen 4x screws on the pump head and Clean the impeller / remove dirt.
Insufficient heat	Indicating one value	Poor performance of motor pump	Raise inlet pressure of motor pump

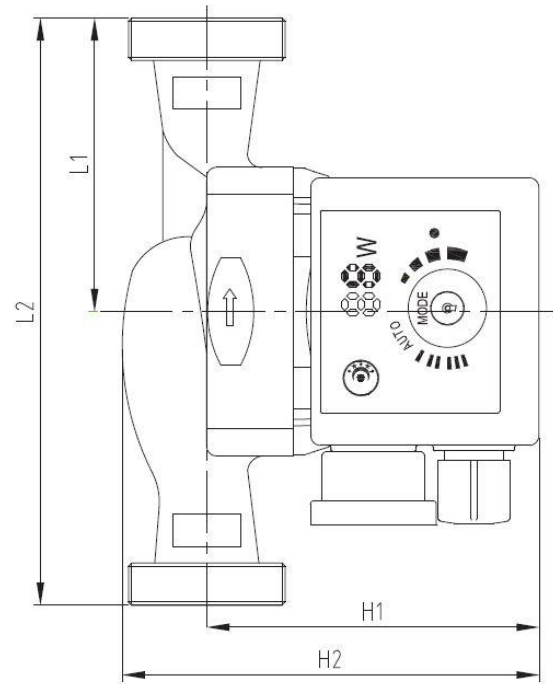
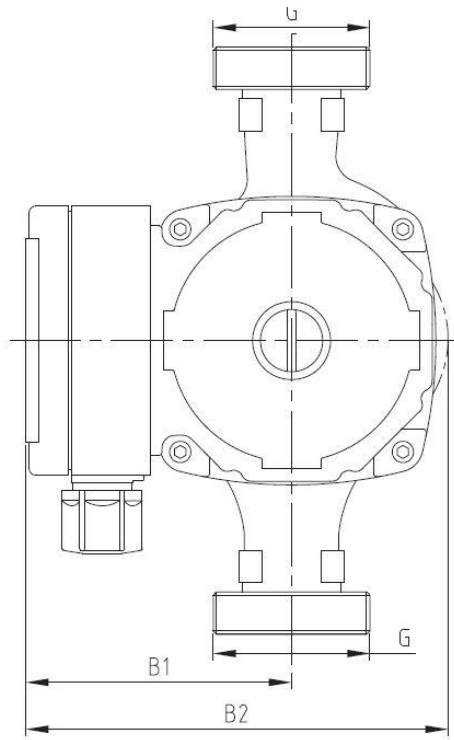

success has a name . . .

HST

AUSTRIA



Meaning of crossed –out wheeled dustbin:

Do not dispose of electrical appliances as unsorted municipal waste, use separate collection facilities.

Contact your local government for information regarding the collection systems available.

If electrical appliances are disposed of in landfills or dumps, hazardous substances can leak into the groundwater and get into the food chain, damaging your health and well-being.

When replacing old appliances with new ones, the retailer is legally obligated to take back your old appliance for disposals at least free of charge.

Product warranty book of HST

HST Heiz- und Sanitärtechnik GmbH provides 12 months' quality assurance for the products since the sales date, and shall be responsible for the product failure or damage caused by manufacturing and material defects. The warranty is on condition that the installation of product should be in line with *HST Installation and Use Manual* and recognized good operation specification.

This warranty does not apply to the product failure or damage caused by ① use the product other than for the usage recommended by HST; ② misuse of the product that does not conform to *HST Installation and Use Manual*; ③ improper maintenance and handling of product; ④ disassemble products and replace parts by oneself.

Any product provided rather than manufactured by HST Heiz- und Sanitärtechnik GmbH should comply with the quality assurance provisions of the manufacturer.

Within warranty period, the product repair is guaranteed by purchase invoice and warranty bill. Please send or return the product in need of repair to the local dealer of HST Heiz- und Sanitärtechnik GmbH. or designated maintenance point for repair. HST Heiz- und Sanitärtechnik. may determine whether home maintenance service shall be provided for free in accordance with its maintenance policies in the local.

HST Heiz- und Sanitärtechnik GmbH. will not accept claims to damage which should be borne by a third party or caused by product failure of any other company.

HST Heiz- und Sanitärtechnik GmbH shall not be responsible for the product failure or damage due to abnormal operating conditions, war, riot, wind (rain) storm, disaster or other force majeure.

HST Heiz- und Sanitärtechnik GmbH reserves the power of interpretation on the unaccomplished matter in the product warranty book.

HST HEIZ- UND SANITÄRTECHNIK GMBH
Ziegeleistraße 1, 5020 Salzburg, AUSTRIA